

## TECHNICAL DATA

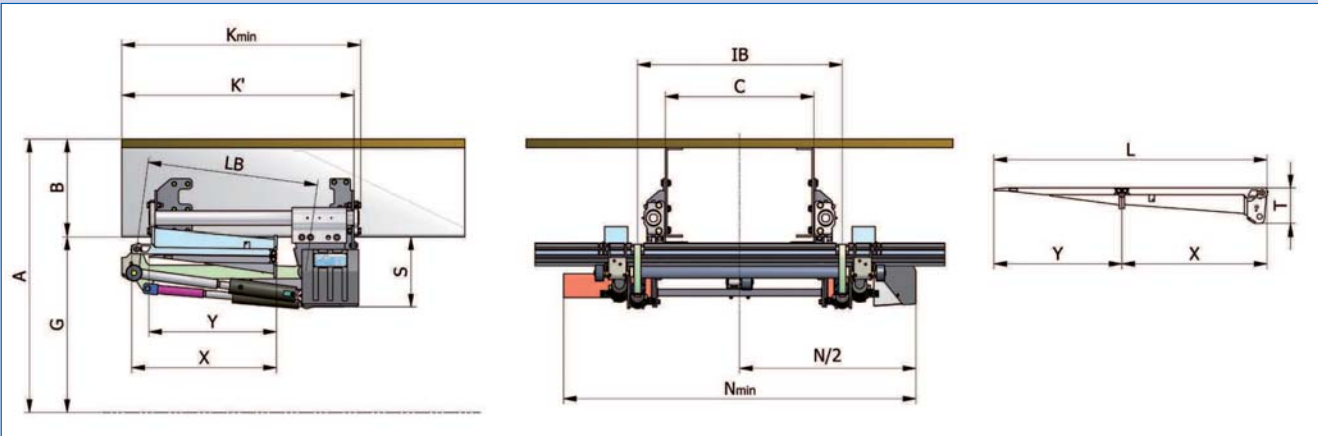

Lift type	Arms width		Arms length		Max width		Power pack clearance		Max floor height		Max B dimensions		Room clearance		Installation distance		Max dimension from under chassis to ground		Platform length		Platform base length		Platform tip length		Platform overhang		Chassis width		Under chassis clearance		Own weight	
	IB	LB	N min	N/2	A max	B max	K min	K'	G max	G min	L	X	Y	T	C min	C max	S	M														
	mm	mm	mm	mm	mm	mm	mm	mm	mm	mm	mm	mm	mm	mm	mm	mm	mm	mm														
RD1-1700	01	1200	800	2070	1035	1328	498	1200	1160	830	677	1400	750	650	215	740	870	385	545													
RD1-1700	02	1450	800	2320	1160	1328	498	1200	1160	830	677	1400	750	650	215	740	870	385	560													
RD1-1700	03	1200	900	2070	1035	1517	581	1300	1260	936	732	1500	800	700	215	740	870	385	555													
RD1-1700	04	1450	900	2320	1160	1517	581	1300	1260	936	732	1500	800	700	215	740	870	385	570													
RD1-1700	05	1200	900	2070	1035	1517	581	1300	1260	936	732	1600	850	750	215	740	870	385	565													
RD1-1700	06	1450	900	2320	1160	1517	581	1300	1260	936	732	1600	850	750	215	740	870	385	580													
RD1-1700	07	1200	1000	2070	1035	1677	641	1400	1360	1036	788	1500	800	700	215	740	870	385	565													
RD1-1700	08	1450	1000	2320	1160	1677	641	1400	1360	1036	788	1500	800	700	215	740	870	385	580													
RD1-1700	09	1200	1000	2070	1035	1677	641	1400	1360	1036	788	1600	850	750	215	740	870	385	575													
RD1-1700	10	1450	1000	2320	1160	1677	641	1400	1360	1036	788	1600	850	750	215	740	870	385	590													
RD1-2200	01	1200	800	2070	1035	1328	498	1200	1160	830	677	1400	750	650	215	740	870	385	555													
RD1-2200	02	1450	800	2320	1360	1328	498	1200	1160	830	677	1400	750	650	215	740	870	385	570													
RD1-2200	03	1200	900	2070	1035	1517	581	1300	1260	936	732	1500	800	700	215	740	870	385	565													
RD1-2200	04	1450	900	2320	1360	1517	581	1300	1260	936	732	1500	800	700	215	740	870	385	580													
RD1-2200	05	1200	900	2070	1035	1517	581	1300	1260	936	732	1600	850	750	215	740	870	385	575													
RD1-2200	06	1450	900	2320	1360	1517	581	1300	1260	936	732	1600	850	750	215	740	870	385	590													
RD1-2200	07	1200	1000	2070	1035	1677	641	1400	1360	1036	788	1500	800	700	215	740	870	385	575													
RD1-2200	08	1450	1000	2320	1360	1677	641	1400	1360	1036	788	1500	800	700	215	740	870	385	590													
RD1-2200	09	1200	1000	2070	1035	1677	641	1400	1360	1036	788	1600	850	750	215	740	870	385	585													
RD1-2200	10	1450	1000	2320	1360	1677	641	1400	1360	1036	788	1600	850	750	215	740	870	385	600													

**PLATFORM LIP:** WHEN APPLIED THE "K" MEASURE IS REDUCED BY 50 MM WHILE THE PLATFORM LENGTH "LU" IS INCREASED BY 50 MM.

**HYDRAULIC STABILIZERS:** WHEN APPLIED THE "K" MIN MEASURE DOES NOT CHANGE.

Weights and dimensions indicated in the catalogue can vary with different lift settings. Car Oil System reserves the right to change above specifications without prior notification. All dimensions are in mm if not different stated. All capacities refer to a load center of 600 mm. Car Oil System is not liable for damages that can be related to variation of above stated weights and dimensions.